



TZ

DIN 3761-BS	
NATIONAL	25



El perfil TZ es un retén radial para sellado de eje compuesto de una sola jaula metálica externa con un revestimiento interno y al final de goma, un labio primario de estanqueidad con muelle integrado y un labio anticontaminación adicional.

The TZ profile is a shaft seal composed of a single external metal cage with an internal and the end rubber coating, a primary sealing lip with integrated spring and an additional anti-pollution lip.

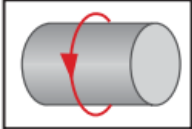

∅	°C	bar	Vel.
10-790 mm	-55°C / 225°C	≤ 0.3 bar	≤ 10 m/s

- Buena rigidez radial, particularmente para grandes diámetros.
- Buena estabilidad cuando se ensambla, para prevenir el efecto rebote.
- Buena compensación de expansión térmica.
- Buena transferencia de calor.
- Sellado para fluidos de baja y alta viscosidad.
- Diseño moderno de labio de sellado primario para obtener fuerzas radiales bajas.
- Protección contra contaminantes aéreos no deseados.

- Good radial rigidity, particularly for large diameters.
- Good stability when assembled, preventing the bounce-back effect.
- Good thermal expansion compensation.
- Good heat transfer.
- Sealing for low and high viscosity fluids.
- Modern primary sealing lip with low radial forces.
- Protection against undesirable air contaminants.

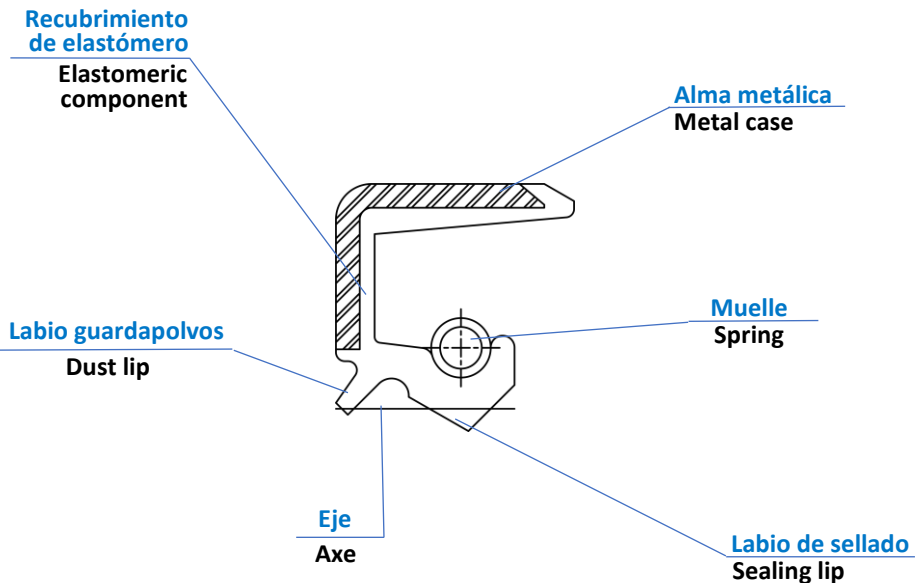

MATERIALES · MATERIALS

- NBR 70-75 Shore A
- HNBR 70-75 Shore A
- FKM 70-75 Shore A
- EPDM 70-75 Shore A
- ACM 70-75 Shore A



AISI 1010 · AISI 304 · AISI 316



AISI 1070-1090 · AISI 316



TOLERANCIAS PARA EL DIÁMETRO EXTERIOR DEL RETÉN
TOLERANCE FOR THE OUTSIDE DIAMETER OF THE SEAL

∅			
∅ ≤ 50.0	+0.10 / +0.20	+0.15 / +0.30	+0.20 / +0.40
∅ <50.0 ≤80.0	+0.13 / +0.23	+0.20 / +0.35	+0.25 / +0.45
∅ <80.0 ≤120.0	+0.15 / +0.25	+0.20 / +0.35	+0.25 / +0.45
∅ <120.0 ≤180.0	+0.18 / +0.28	+0.25 / +0.45	+0.30 / +0.55
∅ <180.0 ≤300.0	+0.20 / +0.30	+0.25 / +0.45	+0.30 / +0.55
∅ <300.0 ≤500.0	+0.23 / +0.35	+0.30 / +0.55	+0.35 / +0.65
∅ <500.0 ≤630.0	+0.23 / +0.35	+0.35 / +0.65	+0.40 / +0.75

TOLERANCIAS PARA EL DIÁMETRO INTERIOR DEL RETÉN
TOLERANCE FOR THE INSIDE DIAMETER OF THE SEAL

El diámetro interior del labio de sellado es siempre menor que el diámetro del eje. Dependiendo del diámetro del eje, el diámetro del labio de sellado es generalmente menor, entre 0,8 y 3,5 mm.

The inside diameter of the sealing lip is always smaller than the diameter of the shaft. Depending on the shaft diameter, the diameter of the sealing lip is generally considered to be less, between 0.8 and 3.5 mm.